

PARTS LIST			
ITEM	PART#	DESCRIPTION	NOTES
1	K1928	2Part 9in Double Face Body	Assembly
2	K1939	2Part Large Ext. Retainer	Assembly
3	K1959/41	2Part Large Inner/Outer Frame	Assembly
4	5980	Header/Reader Divider Angle	
26	5290	2Part Large Ext. Retainer Screw	Drill 1/8" pilot hole
66	5290	Combo Divider Screw	Drill 1/8" pilot hole

ATTACHMENT TO INNER BODY FLANGE

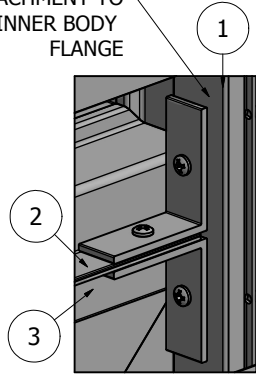

DETAIL A-2

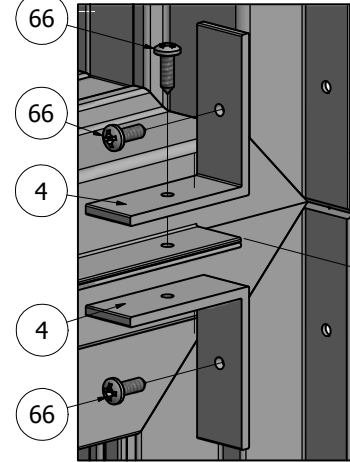

DETAIL A-1

*BOTH THE LG EXT. FRAME AND LG INNER FRAME NEED TO BE NOTCHED WHERE THEY JOIN IN ORDER TO ATTACH TO THE BODY.

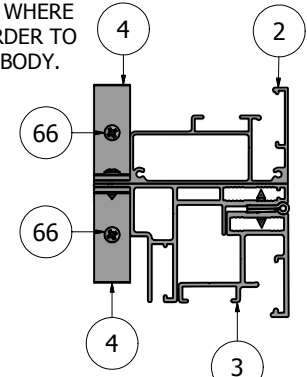

*ANGLES SECURE THE FRAMES ALONG THE HORIZONTALS WHERE THEY JOIN TOGETHER.

Ship To:
Sales Order#:

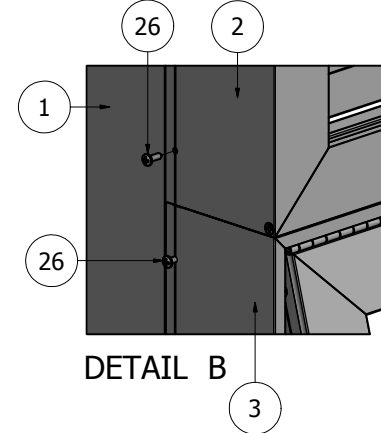
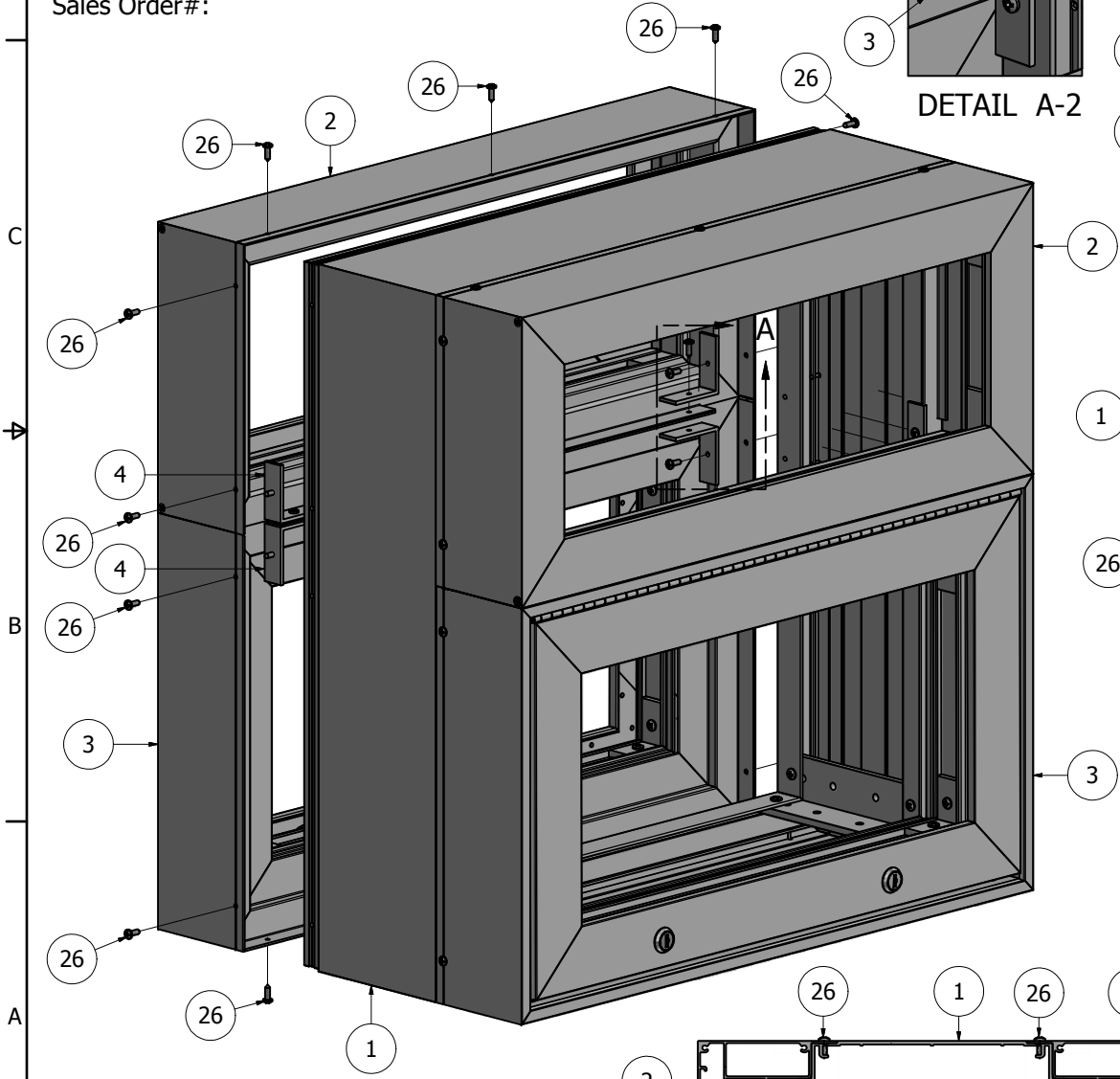

DETAIL B

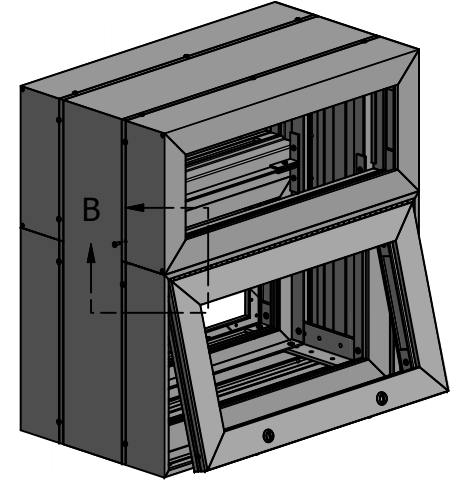

NOTE: PRE-CUT KITS ARE NOT PRE-DRILLED.
(Holes shown in this drawing are for reference only. Drilling of pilot holes are to be done by fabricator.)

THIS DRAWING WAS CREATED AT NO CHARGE TO ASSIST YOU IN VISUALIZING OUR PROPOSAL. THE DRAWING HEREIN IS THE PROPERTY OF SIGNCOMP. PERMISSION TO COPY OR REVISE THIS DRAWING OR TO USE THIS DRAWING FOR PRODUCTION IS STRICTLY PROHIBITED AND CAN ONLY BE COPIED, REVISED OR USED FOR PRODUCTION WITH THE EXPRESSED WRITTEN PERMISSION OF SIGNCOMP.		
DRAWN	SBreihof	8/23/2012
Centroid X:	0.000 in	
Centroid Y:	0.000 in	
Principal Moments Ix:	0.000 in ⁴	
Principal Moments Iy:	0.000 in ⁴	
Section Modulus Ix:	0.000 in ³	
Section Modulus Iy:	0.000 in ³	
SignComp		TITLE
2Part 9in Double Face Body w/ 2Part Large Ext. Retainer and 2Part Large Vandal - Assembly		REV
DWG NO		K1928/39/59/41
SHEET 1 OF 1		

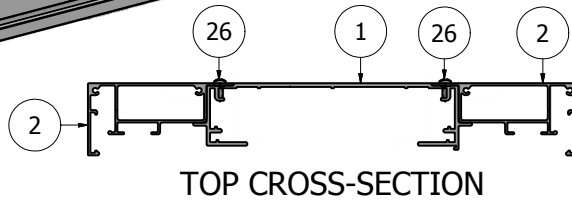

TOP CROSS-SECTION

PARTS LIST			
ITEM	PART #	DESCRIPTION	NOTES
1	1928	2Part 9in Double Face Body	Top & Bottom
2	1928	2Part 9in Double Face Body	Right Side
3	1928	2Part 9in Double Face Body	Left Side
4	5978	Body Corner Angle	
5	5210	Corner Key	
13	5218	Corner Angle Screw	Drill 5/32" pilot hole

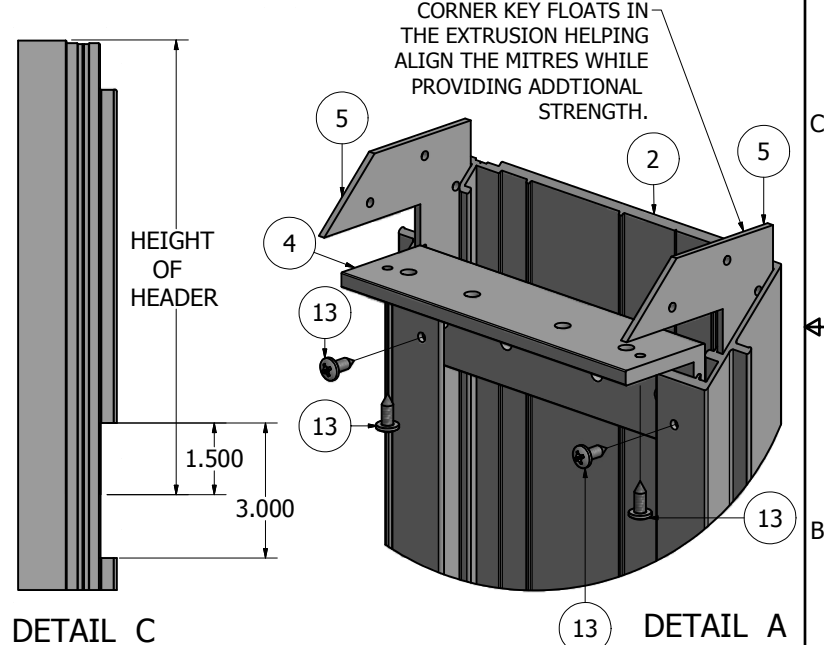
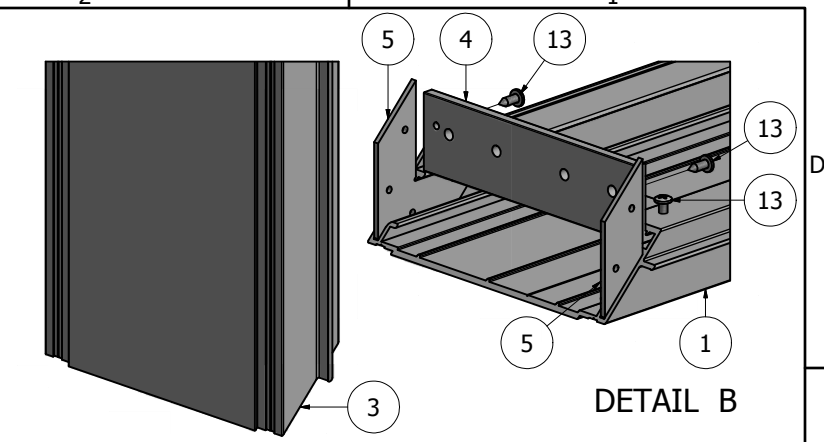
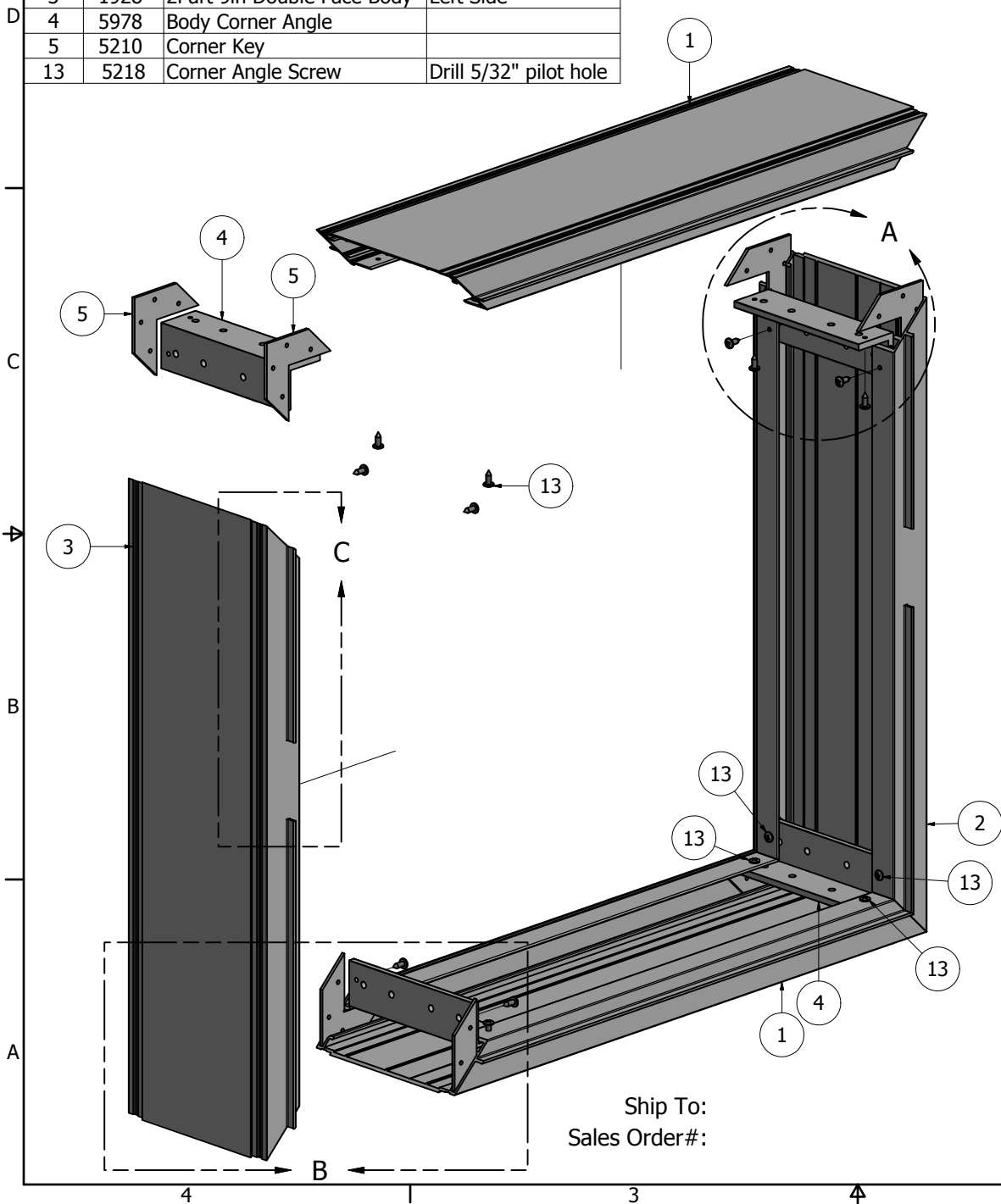

NOTE: PRE-CUT KITS ARE NOT PRE-DRILLED.
 (Holes shown in this drawing are for reference only.
 Drilling of pilot holes are to be done by fabricator.)

THIS DRAWING WAS CREATED AT NO CHARGE TO ASSIST YOU IN VISUALIZING OUR PROPOSAL. THE DRAWING HEREIN IS THE PROPERTY OF SIGNCOMP. PERMISSION TO COPY OR REVISE THIS DRAWING OR TO USE THIS DRAWING FOR PRODUCTION IS STRICTLY PROHIBITED AND CAN ONLY BE COPIED, REVISED OR USED FOR PRODUCTION WITH THE EXPRESSED WRITTEN PERMISSION OF SIGNCOMP.		
DRAWN	SBreihof	7/17/2012
Centroid X:	0.000 in	TITLE
Centroid Y:	0.000 in	
Principal Moments Ix:	0.000 in ⁴	2Part 9in Double Face Body - Notched Assembly
Principal Moments Iy:	0.000 in ⁴	
Section Modulus Ix:	0.000 in ³	DWG NO
Section Modulus Iy:	0.000 in ³	KK1928 - Header / Reader
		REV
		SHEET 1 OF 1

PARTS LIST			
ITEM	PART#	DESCRIPTION	NOTES
1	1939	2Part Large Extended Retainer	Top & Bottom
2	1939	2Part Large Extended Retainer	Sides
3	5210	Corner Key	
4	5305	Frame Corner Angle	
29	5241	2Part Large Ext. Retainer Corner Screw	Drill #8 counter sink

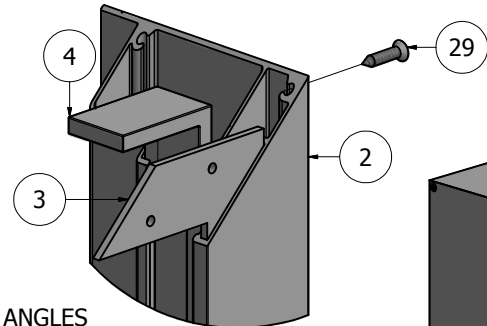

DETAIL A

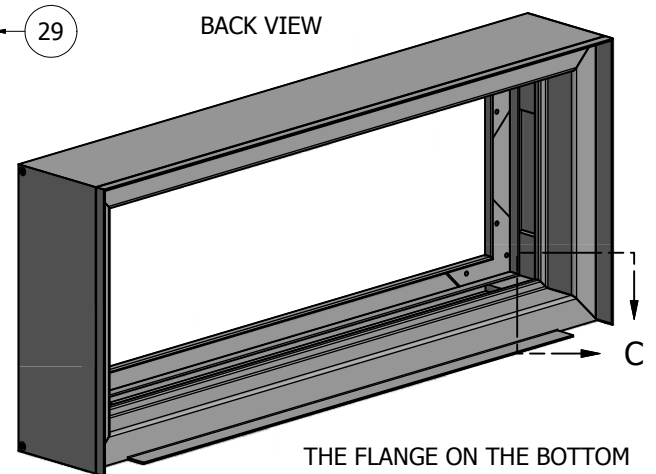

BACK VIEW

THE FLANGE ON THE BOTTOM HORIZONTAL IS NOTCHED ON BOTH ENDS IN ORDER TO FIT AROUND THE BODY FOR ATTACHMENT.

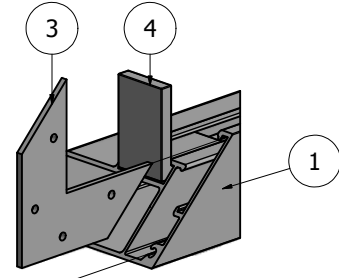

DETAIL B

FRAME CORNER ANGLES AND CORNER KEYS FLOAT IN THE EXTRUSION TO HELP ALIGN THE MITRES AND ADD STRENGTH.

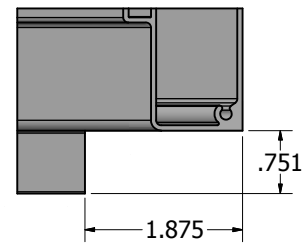

DETAIL C-2

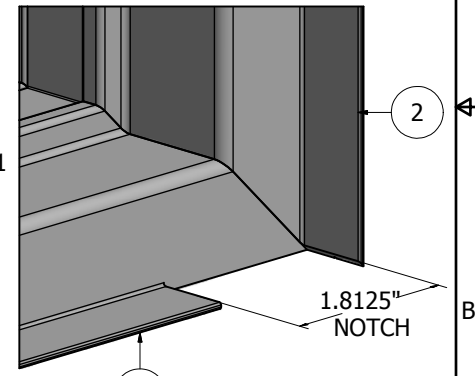

DETAIL C-1

NOTE: PRE-CUT KITS ARE NOT PRE-DRILLED.
(Holes shown in this drawing are for reference only. Drilling of pilot holes are to be done by fabricator.)

THIS DRAWING WAS CREATED AT NO CHARGE TO ASSIST YOU IN VISUALIZING OUR PROPOSAL. THE DRAWING HEREIN IS THE PROPERTY OF SIGNCOMP. PERMISSION TO COPY OR REVISE THIS DRAWING OR TO USE THIS DRAWING FOR PRODUCTION IS STRICTLY PROHIBITED AND CAN ONLY BE COPIED, REVISED OR USED FOR PRODUCTION WITH THE EXPRESSED WRITTEN PERMISSION OF SIGNCOMP.

DRAWN	SBreihof	7/26/2012
Centroid X:	0.000 in	
Centroid Y:	0.000 in	
Principal Moments Ix:	0.000 in ⁴	
Principal Moments Iy:	0.000 in ⁴	
Section Modulus Ix:	0.000 in ³	
Section Modulus Iy:	0.000 in ³	

SignComp		TITLE
		2Part Large Extended Retainer - Header
DWG NO	K1939 - Header	REV
SHEET 1 OF 1		

Ship To:
Sales Order#:

D
C
B
A

D
C
B
A

4
3
2
1

3
2
1

2
1

1

PARTS LIST			
ITEM	PART#	DESCRIPTION	NOTES
1	1959	2Part Large Inner Frame	Top & Bottom Sides
2	1959	2Part Large Inner Frame	Sides
3	5210	Corner Key	
4	5305	Frame Corner Angle	
67	5990	2Part Large Inner Frame Corner Angle Screw	Drill #8 Countersink

Ship To:
Sales Order#:

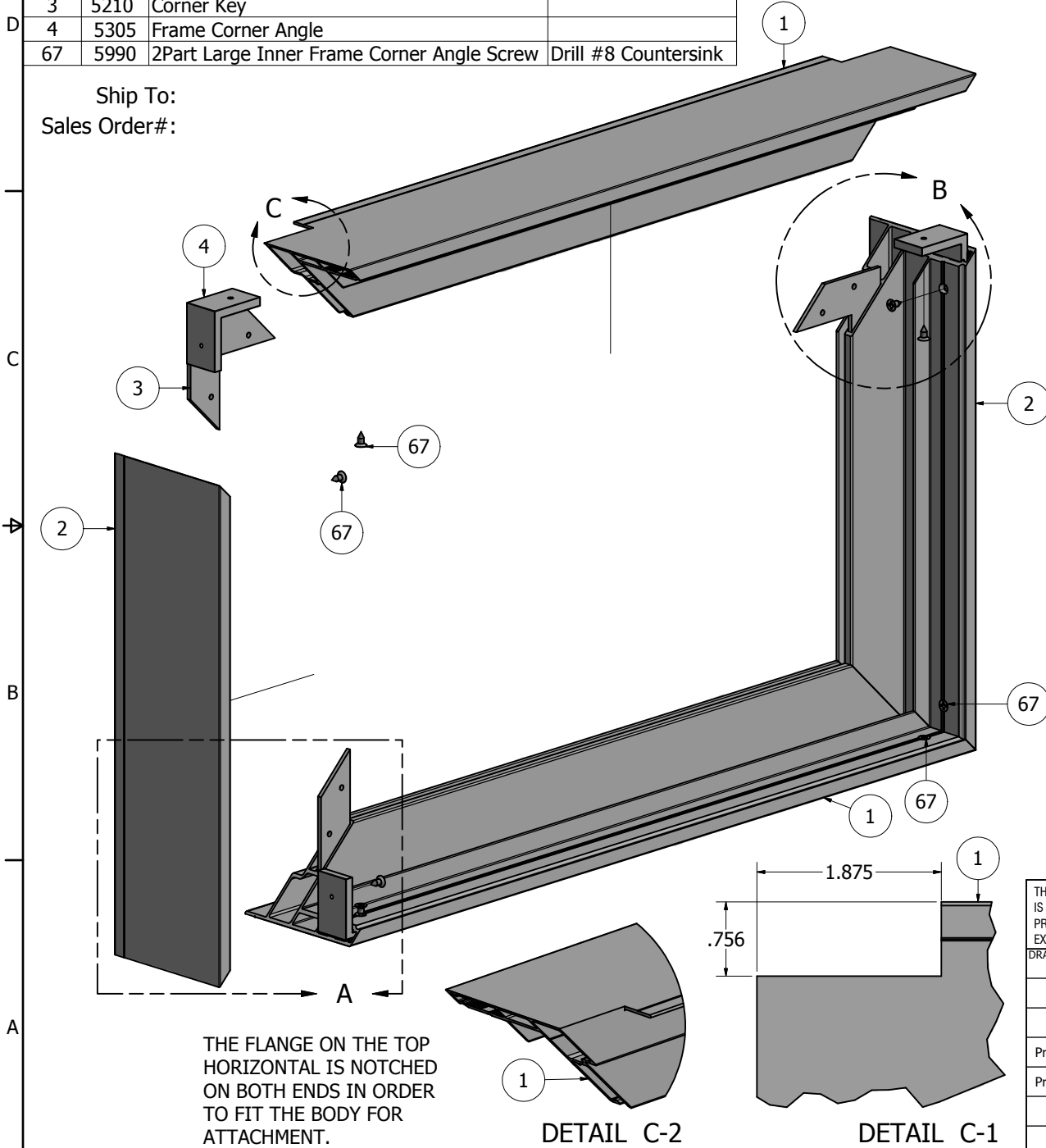

CORNER KEYS FLOAT IN THE FRAME HELPING TO ALIGN THE MITRES WHILE PROVIDING ADDITIONAL STRENGTH.

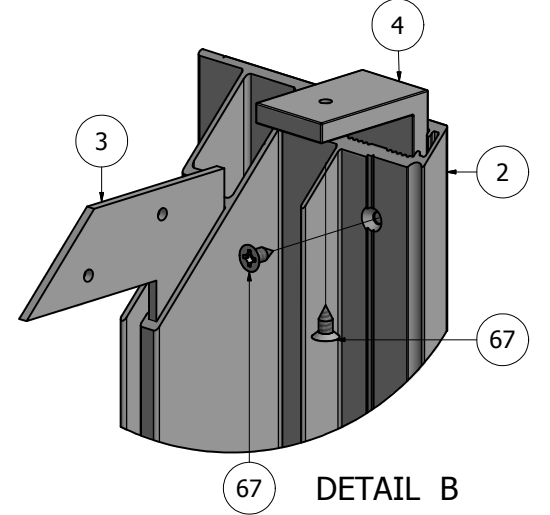
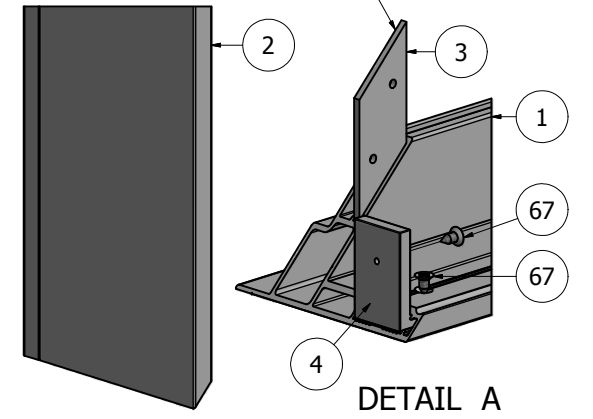

NOTE: PRE-CUT KITS ARE NOT PRE-DRILLED.
(Holes shown in this drawing are for reference only. Drilling of pilot holes are to be done by fabricator.)

THIS DRAWING WAS CREATED AT NO CHARGE TO ASSIST YOU IN VISUALIZING OUR PROPOSAL. THE DRAWING HEREIN IS THE PROPERTY OF SIGNCOMP. PERMISSION TO COPY OR REVISE THIS DRAWING OR TO USE THIS DRAWING FOR PRODUCTION IS STRICTLY PROHIBITED AND CAN ONLY BE COPIED, REVISED OR USED FOR PRODUCTION WITH THE EXPRESSED WRITTEN PERMISSION OF SIGNCOMP.		
DRAWN	SBreihof	7/27/2012
Centroid X:	0.000 in	
Centroid Y:	0.000 in	
Principal Moments Ix:	0.000 in ⁴	
Principal Moments Iy:	0.000 in ⁴	
Section Modulus Ix:	0.000 in ³	
Section Modulus Iy:	0.000 in ³	
SignComp		TITLE
2Part Large Inner Frame - Reader - Assembly		DWG NO
K1959 - Reader		REV
SHEET 1 OF 1		

PARTS LIST			
ITEM	PART #	DESCRIPTION	NOTES
1	1941	2Part Large Outer Frame	Top & Bottom
2	1941	2Part Large Outer Frame	Sides
3	5210	Corner Key	
4	5305	Frame Corner Angle	
13	5218	Corner Angle Screw	Drill #10 pilot hole
30	5990	Outer Frame Corner Angle Screw	Drill #8 Counter Sink

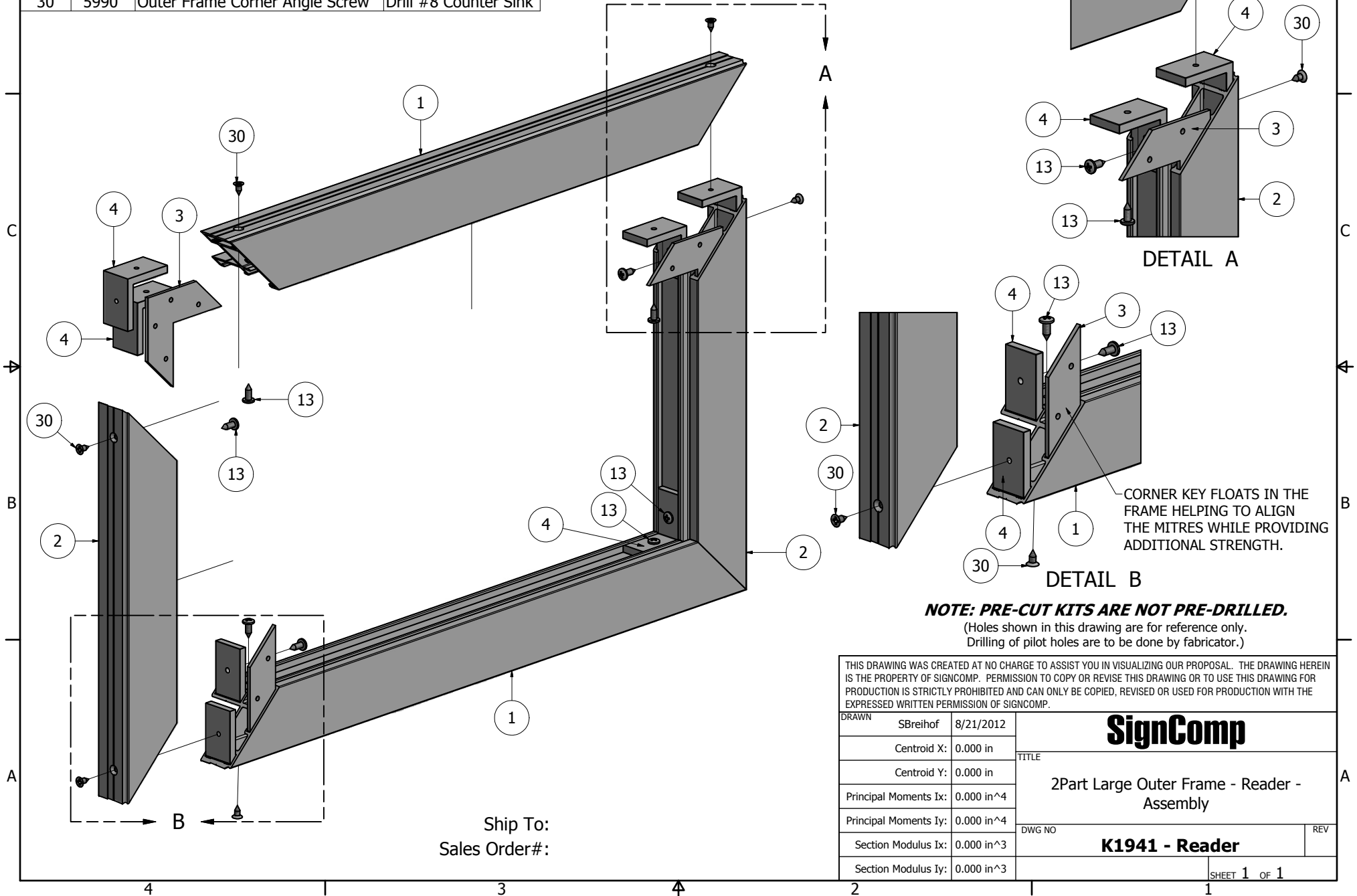

DETAIL A

DETAIL B

CORNER KEY FLOATS IN THE FRAME HELPING TO ALIGN THE MITRES WHILE PROVIDING ADDITIONAL STRENGTH.

NOTE: PRE-CUT KITS ARE NOT PRE-DRILLED.
 (Holes shown in this drawing are for reference only. Drilling of pilot holes are to be done by fabricator.)

THIS DRAWING WAS CREATED AT NO CHARGE TO ASSIST YOU IN VISUALIZING OUR PROPOSAL. THE DRAWING HEREIN IS THE PROPERTY OF SIGNCOMP. PERMISSION TO COPY OR REVISE THIS DRAWING OR TO USE THIS DRAWING FOR PRODUCTION IS STRICTLY PROHIBITED AND CAN ONLY BE COPIED, REVISED OR USED FOR PRODUCTION WITH THE EXPRESSED WRITTEN PERMISSION OF SIGNCOMP.

DRAWN	SBreihof	8/21/2012	SignComp
Centroid X:	0.000 in		
Centroid Y:	0.000 in		TITLE
Principal Moments Ix:	0.000 in ⁴		2Part Large Outer Frame - Reader - Assembly
Principal Moments Iy:	0.000 in ⁴		DWG NO
Section Modulus Ix:	0.000 in ³		K1941 - Reader
Section Modulus Iy:	0.000 in ³		REV

Ship To:
Sales Order#:

PARTS LIST			
ITEM	PART #	DESCRIPTION	NOTES
1	1941	2Part Large Outer Frame	
2		Hinge Fastener	1/8" Pop Rivet or #8 Countersink Screw
3	5997	2Part Large Hinge	
4	5993	2Part Large Lock	Drill 3/4" hole - See Detail "A"
5		Large Lock Nut	
6		Lock Spacer	
7		Large Cam	
8		Sprong Washer	
9		Lock Screw	

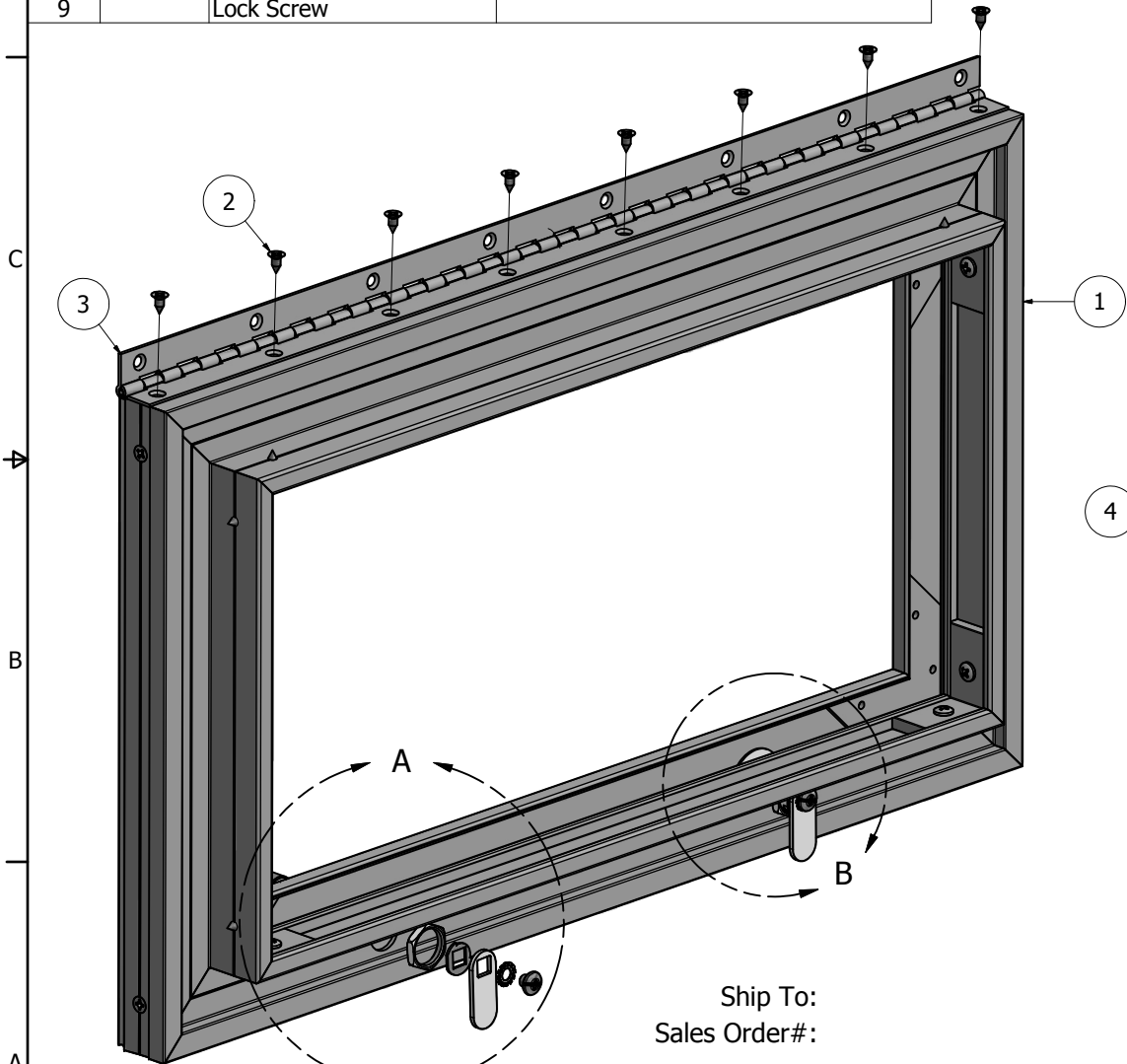

Ship To:
Sales Order#:

TIP: High bond tape or bonding agents can be used to help secure the hinge to the frame and assist in the installation of the hinge. Be careful not to get the tape on the barrel of the hinge. To do so may cause the hinge not to open properly.

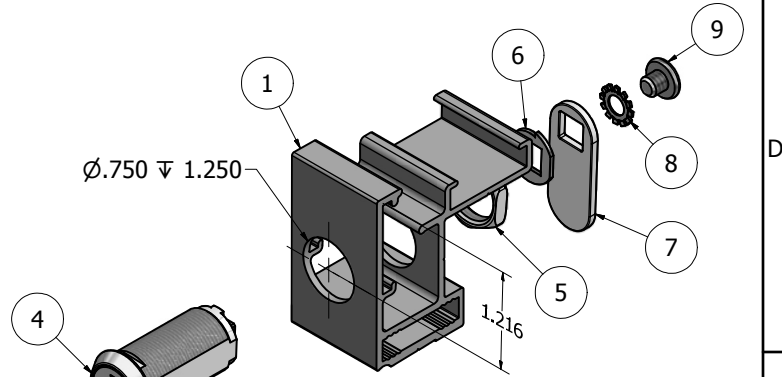

DETAIL A-1

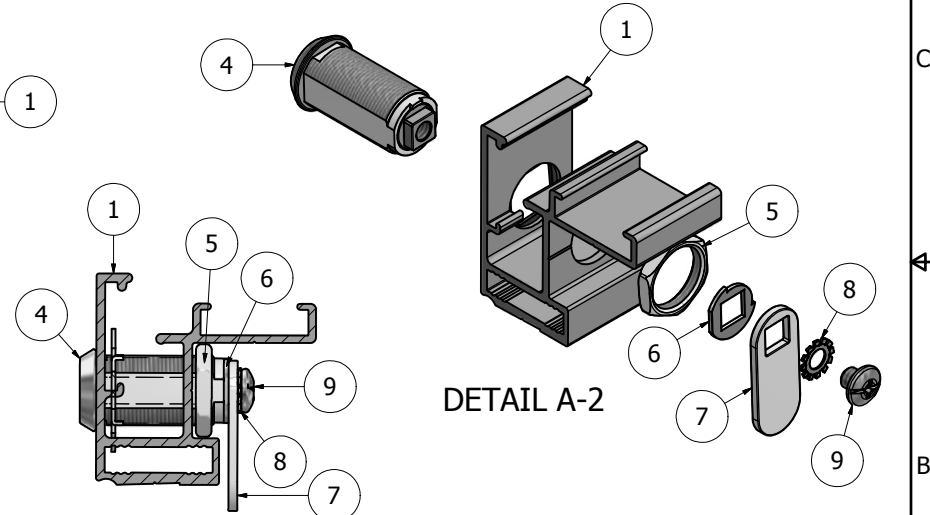

DETAIL A-2

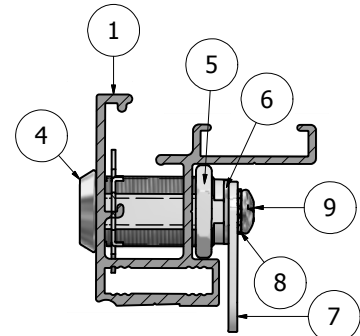

DETAIL B

NOTE: PRE-CUT KITS ARE NOT PRE-DRILLED.
(Holes shown in this drawing are for reference only. Drilling of pilot holes are to be done by fabricator.)

THIS DRAWING WAS CREATED AT NO CHARGE TO ASSIST YOU IN VISUALIZING OUR PROPOSAL. THE DRAWING HEREIN IS THE PROPERTY OF SIGNCOMP. PERMISSION TO COPY OR REVISE THIS DRAWING OR TO USE THIS DRAWING FOR PRODUCTION IS STRICTLY PROHIBITED AND CAN ONLY BE COPIED, REVISED OR USED FOR PRODUCTION WITH THE EXPRESSED WRITTEN PERMISSION OF SIGNCOMP.			<h1 style="text-align: center;">SignComp</h1>	
DRAWN	SBreihof	8/21/2012		
Centroid X:	0.000 in		2Part Outer Frame - 2Part Hinge - 2Part Lock - Reader Assembly	
Centroid Y:	0.000 in			
Principal Moments Ix:	0.000 in^4		DWG NO	REV
Principal Moments Iy:	0.000 in^4		K1941 - Hinge - Lock - Assembly	
Section Modulus Ix:	0.000 in^3			
Section Modulus Iy:	0.000 in^3		SHEET 1 OF 1	

PARTS LIST			
ITEM	PART#	DESCRIPTION	NOTES
1	K1959	2Part Large Inner Frame	Assembly
2	K1941	2Part Large Outer Frame	Assembly
31	5990	2Part Large Hinge Screw	Drill #8 countersink or 1/8" pop rivet

Ship To:
Sales Order#:

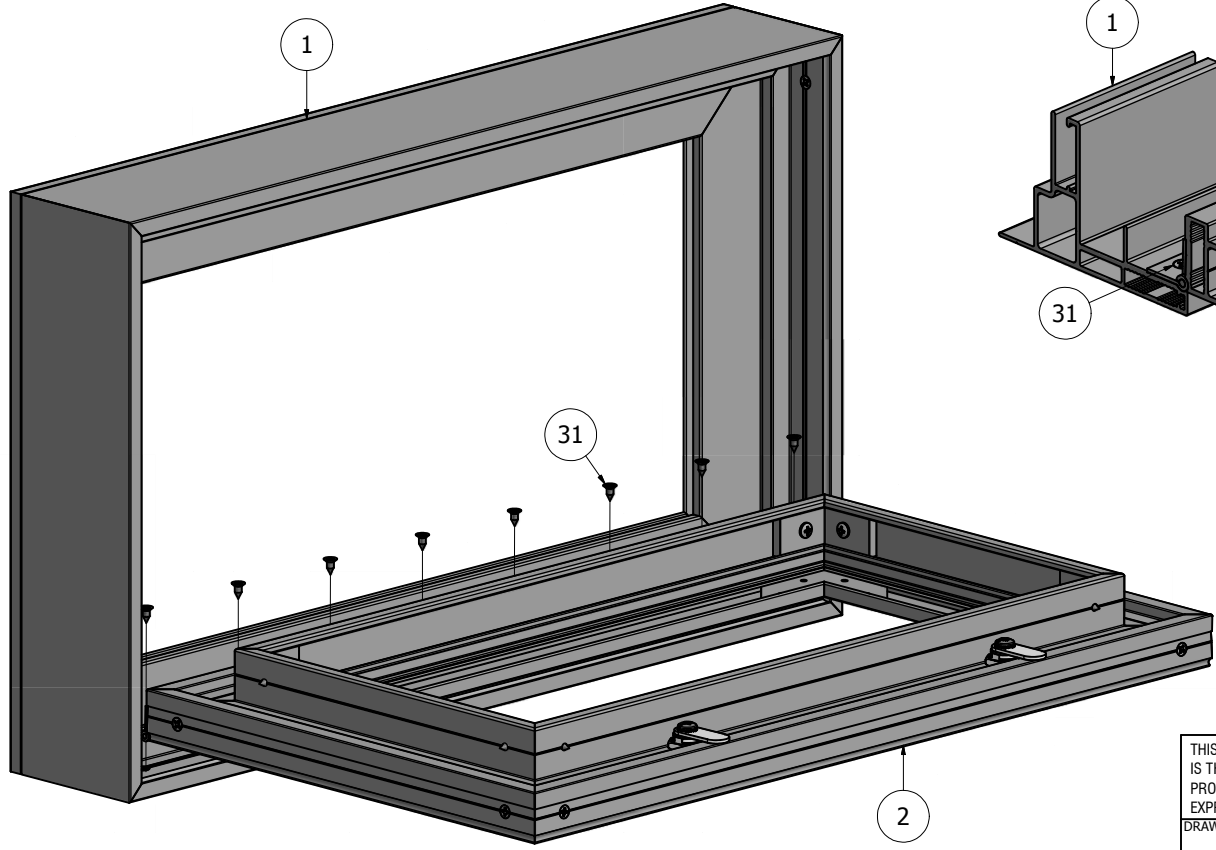
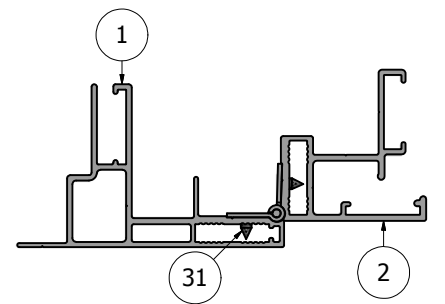
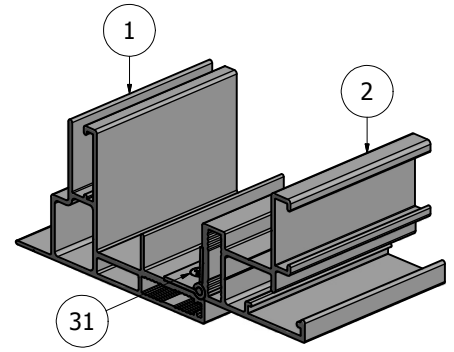
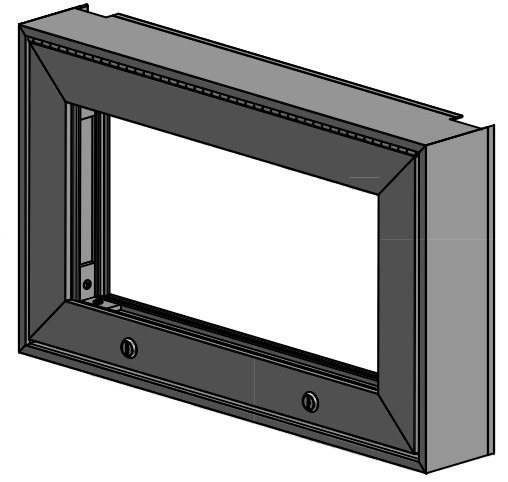
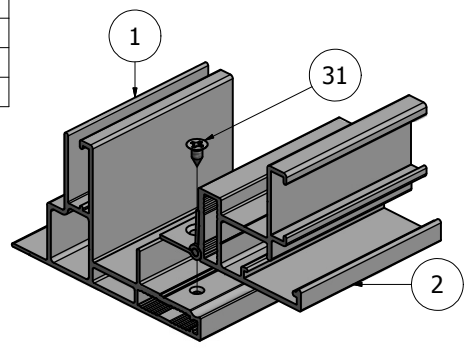

NOTE: PRE-CUT KITS ARE NOT PRE-DRILLED.
(Holes shown in this drawing are for reference only.
Drilling of pilot holes are to be done by fabricator.)

TIP: High bond tape or bonding agents can be used to help secure the hinge to the frame and assist in the installation of the hinge. Be careful not to get the tape on the barrel of the hinge. To do so may cause the hinge not to open properly.

THIS DRAWING WAS CREATED AT NO CHARGE TO ASSIST YOU IN VISUALIZING OUR PROPOSAL. THE DRAWING HEREIN IS THE PROPERTY OF SIGNCOMP. PERMISSION TO COPY OR REVISE THIS DRAWING OR TO USE THIS DRAWING FOR PRODUCTION IS STRICTLY PROHIBITED AND CAN ONLY BE COPIED, REVISED OR USED FOR PRODUCTION WITH THE EXPRESSED WRITTEN PERMISSION OF SIGNCOMP.		
DRAWN	SBreihof	7/27/2012
Centroid X:	0.000 in	
Centroid Y:	0.000 in	
Principal Moments Ix:	0.000 in^4	
Principal Moments Iy:	0.000 in^4	
Section Modulus Ix:	0.000 in^3	
Section Modulus Iy:	0.000 in^3	
SignComp		TITLE
		2Part Large Inner Frame and 2Part Large Outer Frame - Reader Assembly
DWG NO		REV
K1959/41		
SHEET 1 OF 1		